

## 5Z3433AW55ENZ1NQ

- ◆ Outline(L\*W\*H): 3.4\*3.3\*1.92 mm
- ◆ High flux efficiency & offer a middle power
- ◆ Good thermal dissipation & optical uniformity



### Table of Contents

|  |    |
|--|----|
| Product Code Method -----                  | 2  |
| Maximum Rating-----                        | 2  |
| Typical Product Characteristics-----       | 3  |
| Range of Bins-----                         | 3  |
| Color Coordinate Comparison-----           | 4  |
| Electronic-optical Characteristics-----    | 5  |
| Dimensions-----                            | 6  |
| Reflow Profile-----                        | 7  |
| Test Circuit and Handling Precautions----- | 8  |
| Packing-----                               | 9  |
| Precautions-----                           | 11 |
| Test Items and Results of Reliability----- | 12 |

### Features

- Forward current:  $\leq 240\text{mA}$
- Typical view angle 50% Iv:  $120^\circ$
- RoHS and REACH-compliant
- Lens color: yellowish
- MSL 3 qualified according to JEDEC J-STD20D
- ESD Level 6KV(HBM)
- Reliability Test: AEC Q-101 qualified

### Applications

- Indoor signage display applications
- Indoor decorating and entertainment design
- Flat backlight for LCD. Switch and symbol
- Automotive electronics
- Special applications

**■ Product Code Method**

5 - Z - 3433 - A - W55E - N - Z - 1 - N - Q

① ② ③ ④ ⑤ ⑥ ⑦ ⑧ ⑨ ⑩

| ①                  | ②                   | ③                  | ④          | ⑤                               | ⑥                          |
|--------------------|---------------------|--------------------|------------|---------------------------------|----------------------------|
| Process Type       | Category            | Lead Frame Size    | View Angle | Dice Wavelength & Luminous Rank | COB or Bracket Module Code |
| 5: special product | Z: SMD<br>Power LED | 3433:<br>3.4*3.3mm | A: 120°    | Wxxx: white                     | N: article mode            |

| ⑦            | ⑧  | ⑨                 | ⑩                       |
|--------------|--|-------------------|-------------------------|
| CRI or Zener | Assembly Code                            | Process Code      | Spectral Condition Code |
| Z: Zener     | 1: company code for<br>different meaning | N: PLCC procedure | Q: 140mA for test       |

**■ Maximum Rating(Ta=25°C)**

| Characteristics                              | Symbol           | Rating  | Unit |
|--|------------------|---------|------|
| DC forward current                           | I <sub>F</sub>   | 240     | mA   |
| Pulse forward current <sup>*3</sup>          | I <sub>PF</sub>  | 300     | mA   |
| Reverse voltage                              | V <sub>R</sub>   | 5       | V    |
| Junction temperature                         | T <sub>J</sub>   | 125     | °C   |
| Operating temperature range                  | T <sub>OP</sub>  | -40-105 | °C   |
| Storage temperature range                    | T <sub>STG</sub> | -40-105 | °C   |
| Soldering temperature <sup>*4</sup>          | T <sub>SD</sub>  | 260     | °C   |
| Thermal Resistance Junction/<br>Solder Point | R <sub>th</sub>  | 40      | °C/W |

Notes 1: There is no maximum or typical voltage parameter

2: For other ambient, limited setting of current will be depended on de-rating curves.

3: Duty 1/10, pulse width 0.1ms

4: The maximum of soldering time is 5 seconds in T<sub>SD</sub>

**■ Typical Product Characteristics (Ta=25°C)**

| Characteristics    | Symbol            | Min.  | Typ.   | Max. | Unit | Test condition        |
|--------------------|-------------------|-------|--------|------|------|-----------------------|
| Forward Voltage    | V <sub>F</sub>    | 2.7   | 3.1    | 3.9  | V    | I <sub>F</sub> =140mA |
| Reverse Current    | I <sub>R</sub>    | -     | -      | 10   | μA   | V <sub>R</sub> =5V    |
| Luminous Intensity | I <sub>V</sub>    | 10100 | 13130  | -    | mcd  | I <sub>F</sub> =140mA |
| Luminous Lumen     | Φ                 | -     | 34     | -    | lm   | I <sub>F</sub> =140mA |
| View Angle         | 2θ <sub>1/2</sub> | -     | 120    | -    | deg  | I <sub>F</sub> =140mA |
| Color Coordinate   | x                 | -     | 0.5751 | -    | -    | I <sub>F</sub> =140mA |
|                    | y                 | -     | 0.415  | -    | -    |                       |

Notes: 1. Measurement Errors:

Forward Voltage: ±0.1V, Luminous Lumen: ±10%Φ, View Angle: ±5%, Color Coordinate (x, y) ± 0.006

2. Electrical-Optical characteristics (Ta=25°C)

**■ Range of Bins**
**1). Forward Voltage Bins (I<sub>F</sub>=140mA)**

| Bin Code | Min. V <sub>F</sub> (V) | Max. V <sub>F</sub> (V) |
|----------|-------------------------|-------------------------|
| H        | 2.7                     | 3.0                     |
| I        | 3.0                     | 3.3                     |
| J        | 3.3                     | 3.6                     |

**2). Luminous Intensity (I<sub>F</sub>=140mA)**

| Bin code | Min. I <sub>V</sub> (mcd) | Max. I <sub>V</sub> (mcd) |
|----------|---------------------------|---------------------------|
| 24       | 10100                     | 13130                     |
| 25       | 13130                     | 17000                     |
| 26       | 17000                     | 22110                     |

**■ Color Coordinate Comparison**

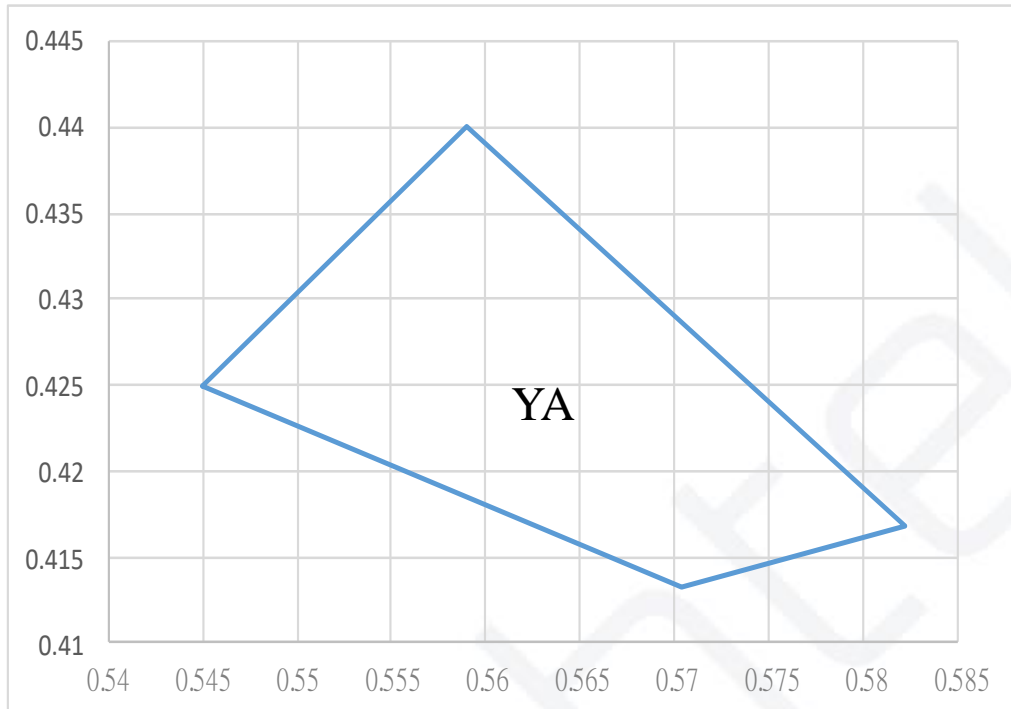

---

**Color Rank**

| Bin code | X     | Y     | X      | Y      | X      | Y      | X     | Y    |
|----------|-------|-------|--------|--------|--------|--------|-------|------|
| YA       | 0.545 | 0.425 | 0.5704 | 0.4132 | 0.5822 | 0.4168 | 0.559 | 0.44 |

Optical Characteristics

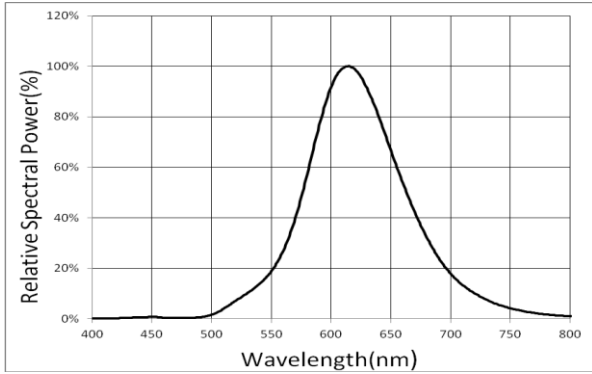
1). Relative Spectral Distribution



2). Typical Spatial Distribution

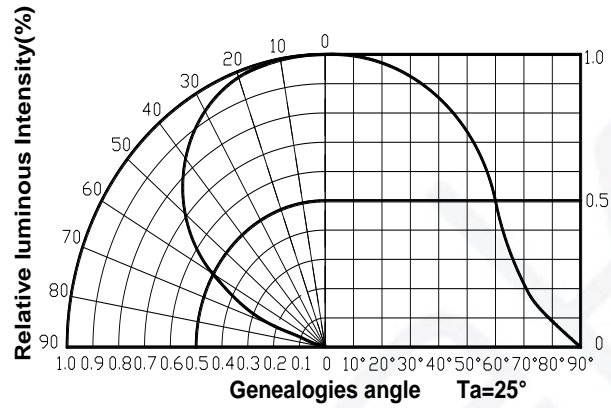

3). Relative Luminous Flux .Current

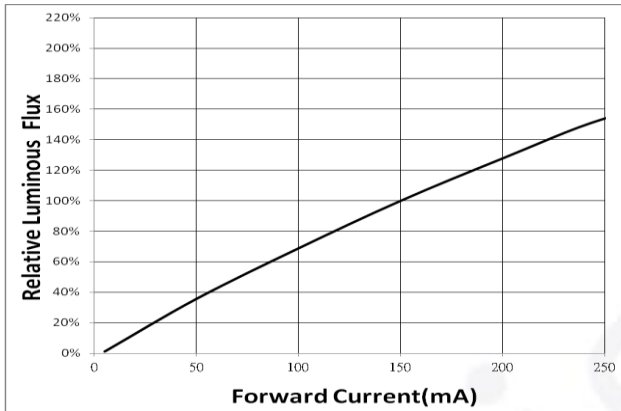

4). Relative Luminous Flux .Ambient Temperature

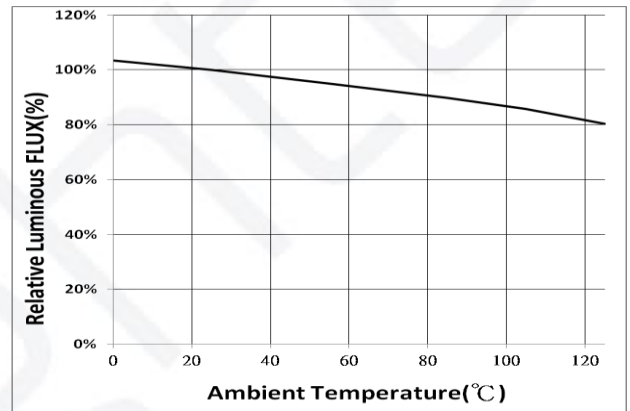

5). Electrical Characteristics

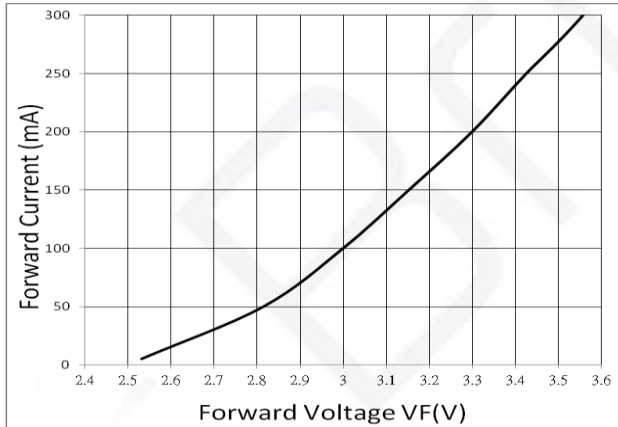

6). Relative Forward Voltage Temperature

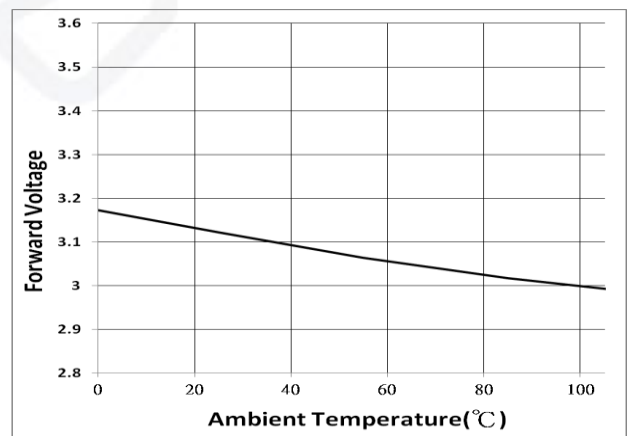

7). Chromaticity Coordinate and Temperature

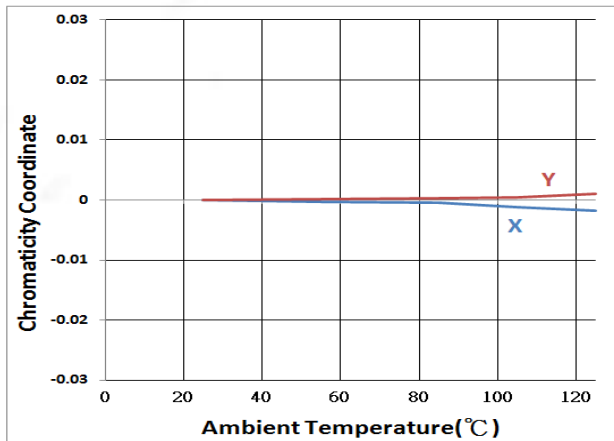

8). Thermal Design

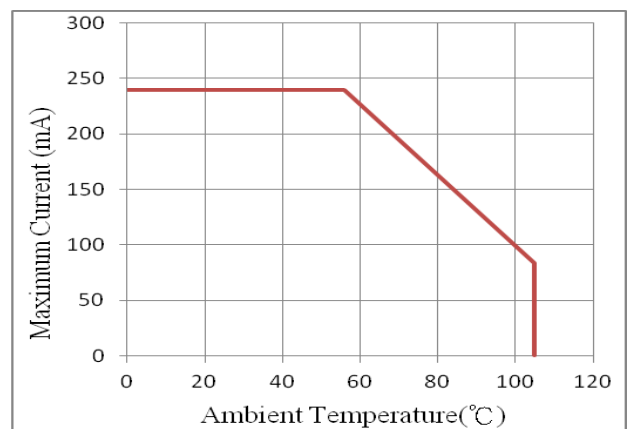

■ Dimensions

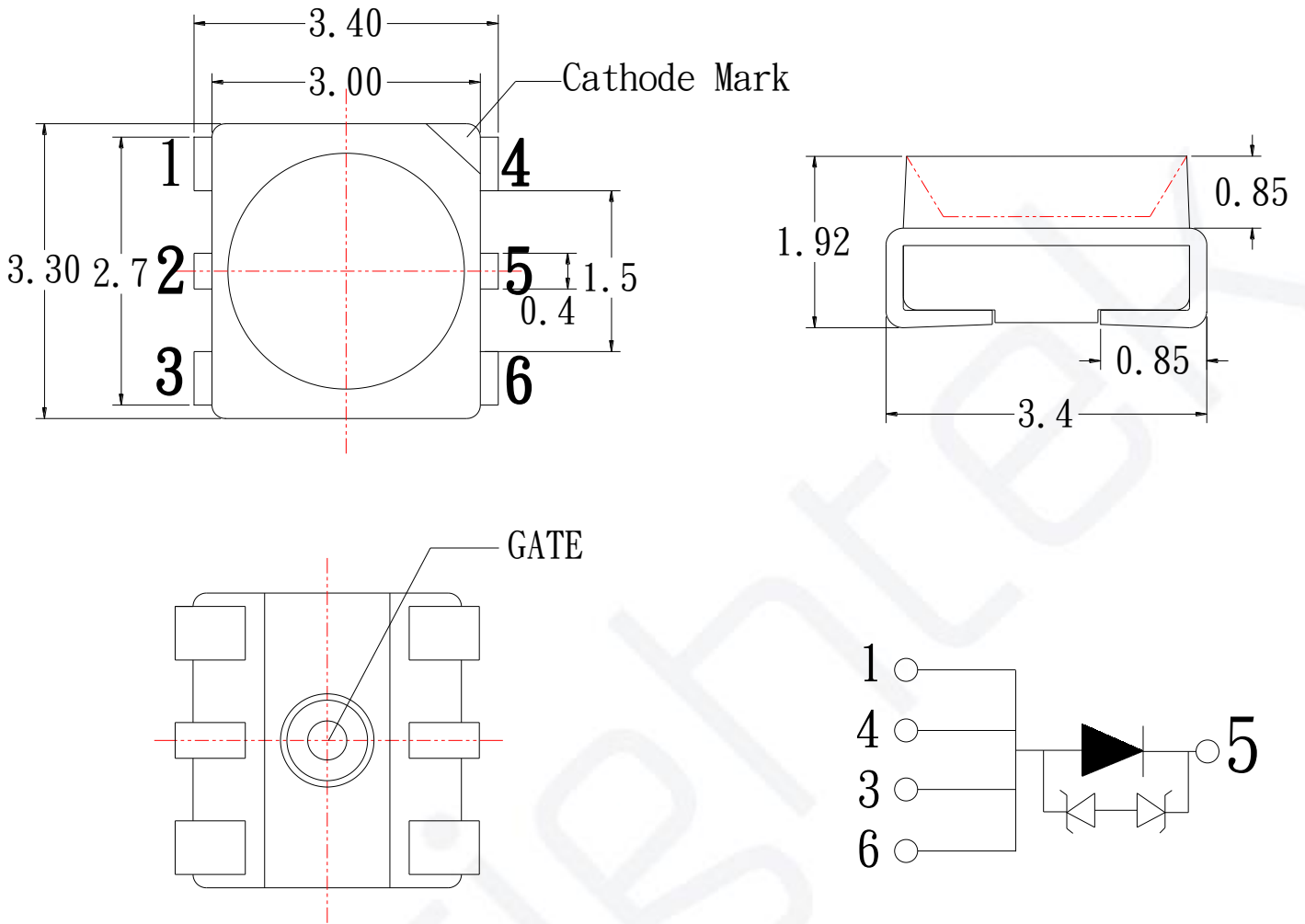

**Recommend Pad layout**

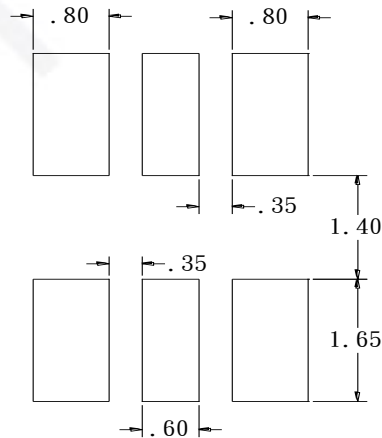

- Notes:
1. All dimensions are in millimeters
  2. Tolerance is  $\pm 0.1\text{mm}$  unless otherwise noted
  3. Specifications are subject to change without notice.

■ **Reflow Profile**

**1. IR reflow soldering Profile for Lead Free solder**

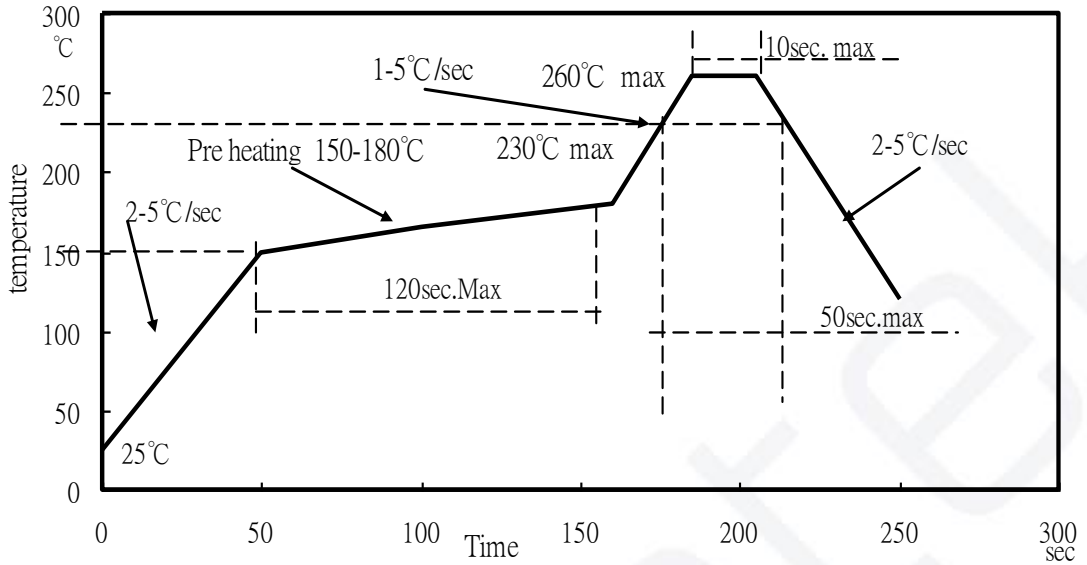

**Notes:**

1. We recommend the reflow temperature 240°C ( $\pm 5^\circ\text{C}$ ).the maximum soldering temperature should be limited to 260°C.
2. Don't cause stress to the silicone resin while it is exposed to high temperature.
3. Number of reflow process shall be less than 3 times.

## ■ Test Circuit and Handling Precautions

---

### 1. Test circuit

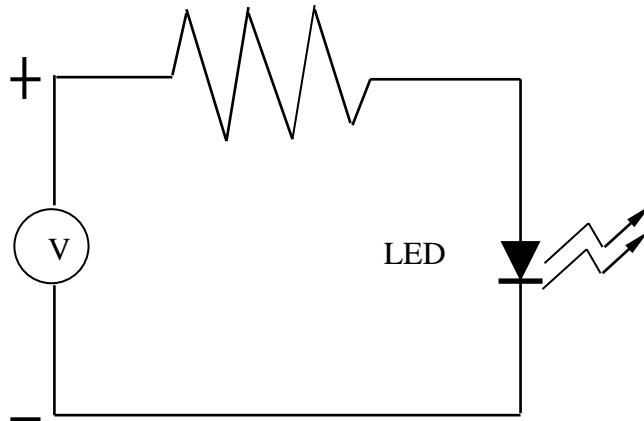

### 2. Handling precautions

#### 2.1. Over-current-proof

Customer must apply resistors for protection; otherwise slight voltage shift will cause big current change (Burn out will happen).

#### 2.2. Storage

1). It is recommended to store the products in the following conditions:

Humidity: 60% R.H. Max.

Temperature: 5°C~30°C (41°F~86°F)

2). Shelf life in sealed bag: 12 month at <5°C~30°C and <60% R.H. after the package is Opened, the products should be used within 1 week or they should be keeping to stored at  $\leq 20\%$ R.H. with zip-lock sealed.

#### 2.3. Baking

If the package has been opened for more than 1 week, it is recommended to bake the products with the following instruction:

1). 60±3°C X 24hrs and <5%RH, for reel

2). 125±3°C X 2hrs, for single LED

It shall be normal to see slight color fading of carrier (light yellow) after baking in process



■ Packing

● Dimensions of Reel (Unit: mm)

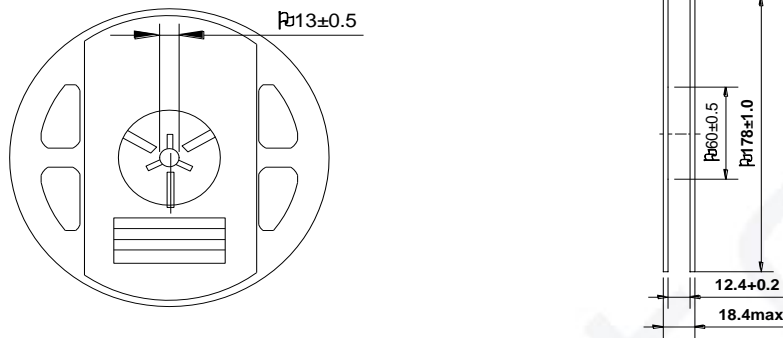

Note: 01.The tolerance unless mentioned is  $\pm 0.1$ mm.  
02.The measured unit is "mm".

● Dimensions of Tape (Unit: mm)

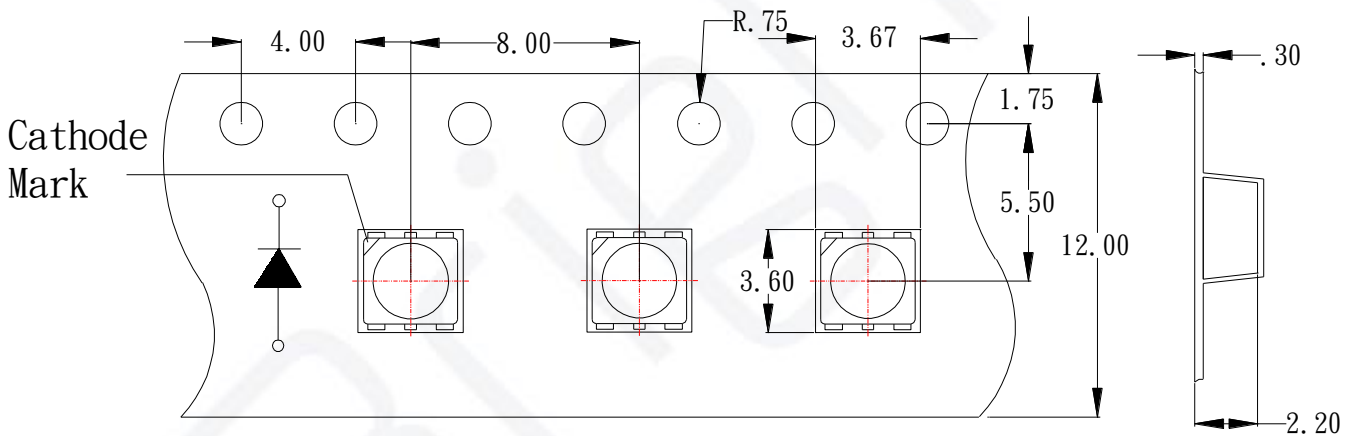

● Arrangement of Tape

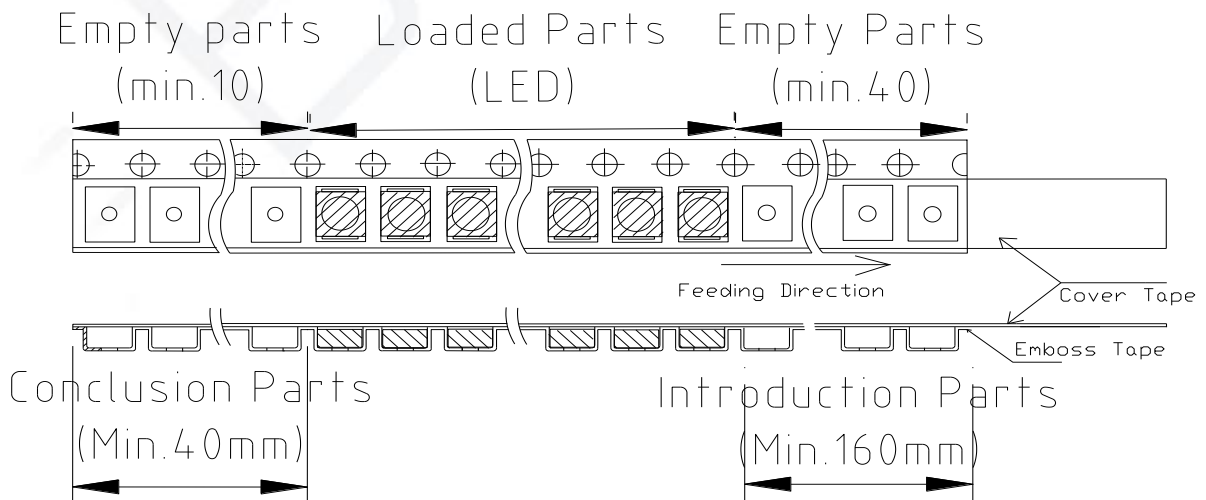

Notes:

1. Empty component pockets are sealed with top cover tape
2. The max loss number of SMD is 2pcs

3. The cathode is oriented towards the tape sprocket hole in accordance with ANSI/EIA RS-481 specifications
4. 1,000pcs per reel

## ■ Packing

---

### ● Packaging Specifications

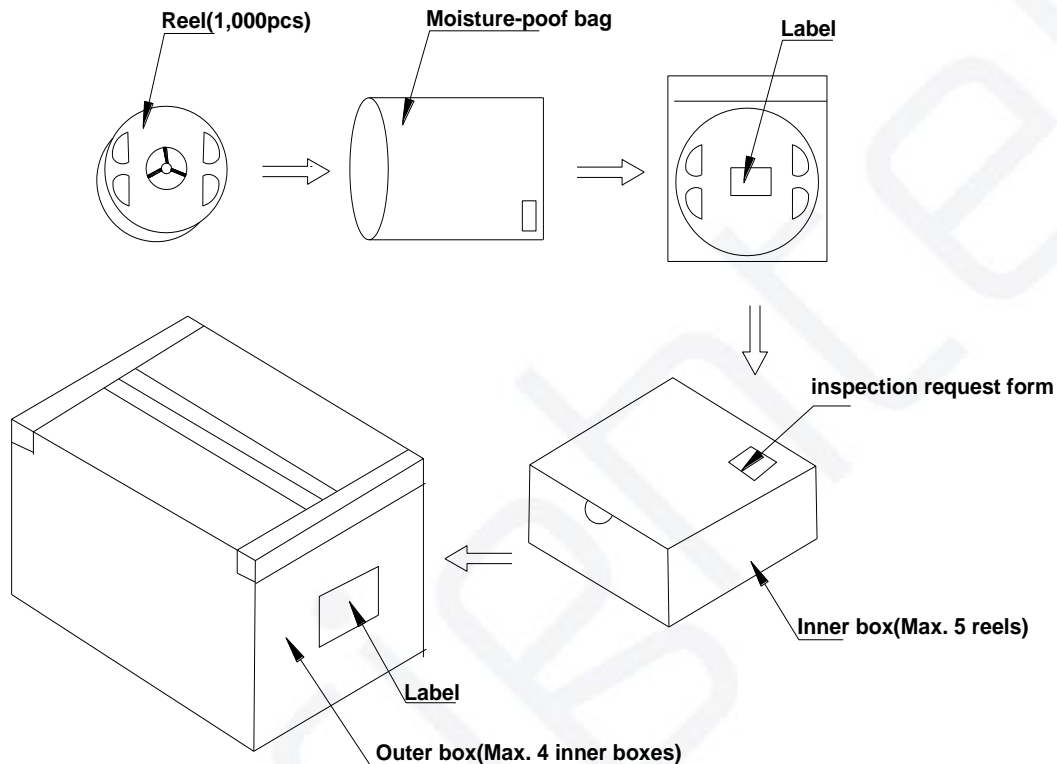

Notes:

Reeled product (max.1,000) is packed in a sealed moisture-proof bag. Five bags are packed in an inner box (size: about 260 X 230 X 100 mm) and four inner boxes are in an outer box (size: about 480 X 275 X 215 mm). On the label of moisture-proof bag, there should be the information of Part No., Lot No. and quantity number; also the total quantity number should be on inspection request form on outer box.

**■ Precautions**

---

**1. Abnormal situation caused by improper setting of collet**

To choose the right collet is the key issue in improving the product's quality. LED is different from other electronic components, which is not only about electrical output but also for optical output. This characteristic made LED more fragile in the process of SMT. If the collet's lowering down height is not well set, it will bring damage to the gold wire at the time of collet's picking up and loading which will cause the LED fail to light up, light up now and then or other quality problems

**2. How to choose the collet**

During SMT, please choose the collet that has larger outer diameter than the lighting area of lens, in case that improper position of collet will damage the gold wire inside the LED. Different collets fit for different products, please refer to the following pictures cross out

**Outer diameter of collet should be larger than the lighting area**

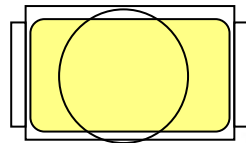

**Picture 1(√)**

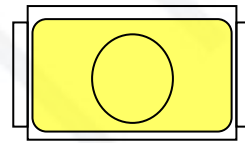

**Picture 2(X)**

**3. Other points for attention**

- A. No pressure should be exerted to the epoxy shell of the SMD under high temperature.
- B. Do not scratch or wipe the lens since the lens and gold wire inside are rather fragile and cross out easy to break.
- C. LED should be used as soon as possible when being taken out of the original package, and should be stored in anti-moisture and anti-ESD package.

**4. This usage and handling instruction is only for your reference.**

**■ Test Items and Results of Reliability**

| Test Item                             | Test Conditions  | Duration/<br>Cycle | Ac/Re | Number of<br>Damage | Reference    |
|---------------------------------------|--|--------------------|-------|---------------------|--------------|
| Normal Temperature Life               | T <sub>a</sub> =23°C (±5°C)<br>I <sub>F</sub> =140mA           | 1008 hrs           | 0/1   | 0/22                | JESD22 A-108 |
| High Temperature Life                 | T <sub>a</sub> =85°C (±5°C)<br>I <sub>F</sub> =140mA           | 1008 hrs           | 0/1   | 0/22                | JESD22 A-108 |
| High Humidity Heat Life               | T <sub>a</sub> =85°C (±5°C)<br>RH=85%<br>I <sub>F</sub> =140mA | 1008 hrs           | 0/1   | 0/22                | JESD22 A-108 |
| Thermal shock                         | -45°C/30min~105°C<br>/30min<br>(±5°C)                          | 1008 hrs           | 0/1   | 0/22                | JESD22 A-104 |
| Electrostatic Discharge (ESD)<br>Test | According to the<br>SPEC                                       | 3 cycles           | 0/1   | 0/22                | AEC Q101-001 |
| Low Temperature Storage               | T <sub>a</sub> =-40°C  | 1008 hrs           | 0/1   | 0/22                | JESD22-A103D |
| High Temperature Storage              | T <sub>a</sub> =125°C  | 1008 hrs           | 0/1   | 0/22                | JESD22-A103D |

| <b>*Criteria for Judging</b> |                |                       |                               |                        |
|------------------------------|----------------|-----------------------|-------------------------------|------------------------|
| Item                         | Symbol         | Condition             | Criteria for Judgment of Pass |                        |
|                              |                |                       | Min                           | Max                    |
| Forward Voltage              | V <sub>F</sub> | I <sub>F</sub> =140mA | -                             | USL* <sup>1</sup> ×1.1 |
| Reverse Current              | I <sub>R</sub> | V <sub>R</sub> = 5V   | -                             | 10μA                   |
| Luminous Intensity           | I <sub>V</sub> | I <sub>F</sub> =140mA | LSL* <sup>2</sup> ×0.7        | -                      |

[Note] USL\*<sup>1</sup>: Upper Specification Level

LSL\*<sup>2</sup>: Lower Specification Level

Brightek